

CLIPPER POOL 160KG
STRUCTURAL CAPACITY DESIGN ASSESSMENT

ASSET ID: _____

SERIAL NUMBER: _____

CLIENT: Polyworld, 14-20 Robson St, Clontarf QLD 4019

Notes:

| Rev | Date | Notes |
|-----|------------|--------------------|
| 0 | 19/07/2023 | APPROVED FOR ISSUE |
| | | |



Austica Pty Ltd

LEADERSHIP IN ENGINEERING

Web: <http://austica.net.au>

Mobile: +61(0)422468514

email: peter.kairu@austica.net.au

Studio: 2/101 Annerley Rd

Woolloongabba

Qld 4102

CLIENT: Polyworld, 14-20 Robson St, Clontarf QLD 4019.

PROJECT: Various as determined by Polyworld.

LOCATION: Various as determined by Polyworld.

ITEM: Clipper Pool 160kg Structure Design Capacity assessments.

ASSET ID: _____. **SERIAL NUMBER:** _____

DATE: 19/07/2023.

COMMENTS:

Polyworld requested a Structural Capacity Design Assessment for a Clipper Pool 160kg Structure. The main fabrication materials consisted of Alkatuff LL711UV Linear Low Density Polyethylene Materials. Nominal wall thickness was 9 to 12mm. Polyworld provided the associated Fabrication Drawings as per the attached PDF.

Austica Pty Ltd then carried out Structural Modelling and Analysis to check Structural Capacity compliance with AS 1170, AS 1170.1, AS 1838, AS 1664.1, AS 4100 and AS 1554.1

The Analysis indicates that the Clipper Pool 160kg Structure design meets the requirements of the above noted Australian Standards, where installed as per the manufacturer recommendations.

Pool installation to be as per AS 1839 specifications. Where the structure is partially or wholly installed into the ground, relevant Engineers including Geotechnical, Structural and Hydraulic Engineers to be consulted to offer specific site pool installation and operation specifications. Site specific Engineering specifications to also consider pool emptying procedures including any necessary internal bracing. Periodic inspections to be undertaken to the Structure and identify any damage. The Structure to be only used when in structurally sound state.

Polyworld to ensure the pool fabrication has been carried out to ISO 9000 QA procedures and that the materials indicated in the fabrication drawings have been utilised.

Sign:



Name: Peter Kairu RPEQ 10198 MIEAust CPEng Chartered Professional Engineer 3473760 NER

Att: Fabrication Drgs PDF

Base Reference: AS 1170, AS 1170.1, AS 1838, AS 1839, AS 1664.1, AS 4100, AS 1554.1

Clipper Pool Drawing

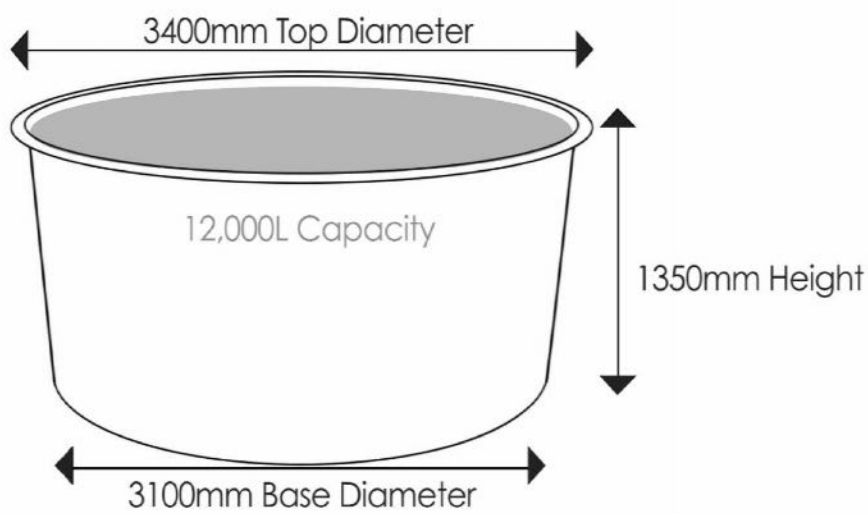

| | Capacity | | Height | | Diameter/Width | |
|---------|----------|---------|--------|----------|----------------|----------|
| | LITRES | GALLONS | METRIC | IMPERIAL | METRIC | IMPERIAL |
| Clipper | 12000 | 3170 | 1350 | 4'4" | 3400 | 11'2" |



CERTIFICATE OF CONFORMITY

SAI Global hereby grants:

Qenos Pty Ltd

62 054 196 771

471 Kororoit Creek Road, Altona, VIC, 3018, Australia

Product Safety Type Test Licence

Evaluated to:

AS/NZS 4766:2020- Rotationally moulded buried, partially buried and non-buried storage tanks for water and chemicals

The Type Test Licensee the right to use the Type Test Certification Trade Mark, as shown below, to those goods manufactured identically to the sample examined conforming to the Standard to Specification above

Certificate No: PST21573

Issued: 08 February 2022

Originally Certified: 30 July 2008

Expires: 29 July 2025

Current Certification: 02 February 2022

Calin Moldovean
President, Business Assurance
SAI Global Assurance



Registered by:

SAI Global Certification Services Pty Ltd (ACN 108 716 669) 680 George Street Sydney NSW 2000 Australia with SAI Global Limited 680 George Street Sydney NSW 2000 Australia ("SAI Global") and subject to the SAI Global Terms and Conditions for Certification. While all due care and skill was exercised in carrying out this assessment, SAI Global accepts responsibility only for proven negligence. This certificate remains the property of SAI Global and must be returned to SAI Global upon its request. To verify that this certificate is current please refer to SAI Global On-Line Certification register at <http://register.saiglobal.com>



DESCRIPTION

Alkatuff LL711UV is a hexene LLDPE material specifically designed for rotational moulding applications that require excellent ESCR, chemical resistance*, stiffness and toughness. Alkatuff LL711UV is UV stabilised to provide prolonged outdoor protection in Australian conditions.

APPLICATION

Alkatuff LL711UV is designed for chemical, diesel fuel and water tanks, as well as other applications where toughness, stiffness and UV protection is important. Alkatuff LL711UV complies with the base resin requirements of AS/NZS 4766 Rotationally moulded buried, partially buried and non-buried storage tanks for water and chemicals.

FOOD CONTACT / PRODUCT SAFETY

For food contact information please refer to the Regulatory Data Sheet at genos.com. For product safety information please refer to the Safety Data Sheet at genos.com.

| Polymer Properties | Value ¹ | Units | Test Method |
|---|--------------------|-------------------|-------------|
| Melt Index @ 190°C, 2.16 kg | 3.0 | g/10 min | ASTM D1238 |
| Density | 0.938 | g/cm ³ | ASTM D1505 |
| Moulding Properties | Value ¹ | Units | Test Method |
| Melting Point | 128 | °C | ASTM D3418 |
| Thermal Stability | Pass | - | AS/NZS 4766 |
| Tensile Strength at Yield ² | 19.5 | MPa | ASTM D638 |
| Flexural Modulus (1% Secant) ³ | 800 | MPa | ASTM D790B |
| ESCR F ₅₀ (Condition A, 100% Igepal) | >1000 | hrs | ASTM D1693 |
| Contact with Drinking Water | Pass | - | AS/NZS 4020 |
| Hydrostatic Design Basis | 8.62 ⁴ | MPa | ASTM D2837 |
| UV Resistance ⁵ | UV20 | - | AS/NZS 4766 |
| Resistance to Diesel Fuel ⁶ | Pass | - | ECE-R34 |

1. Typical values - not to be construed as specifications.

2. At 50 mm/min crosshead speed.

3. At 12.7 mm/min crosshead speed.

4. A service factor must be applied in accordance with AS/NZS 4766.

5. Samples of injection moulded non-pigmented LL711UV retained more than 50% tensile elongation after 20,000 hours of accelerated weathering in Qenos's Xenon-Arc weatherometer. Qenos is accredited by NATA to perform accelerated weathering in accordance with ASTM D2565. UV performance determined via artificial weathering does not translate into a specific outdoor UV lifespan. Many factors can influence the overall UV performance of rotomoulded articles.

6. TÜV Rheinland Kraftfahrt GmbH has certified Alkatuff LL711UV for use in the production of rotationally moulded fuel tanks. The certification applies to petroleum based diesel fuel containing up to 5% biodiesel.

For up to date information, refer to genos.com

* The level of chemical resistance is a function of product design and environmental conditions. Contact Qenos for further information



Type Tested
AS 4768
Lic PST21573
SAI Global

This information is offered solely for your consideration, investigation, verification and shall not be construed as a warranty or representation for which Qenos Pty Ltd assumes legal liability, except to the extent that such liability is imposed by legislation and cannot be excluded. Values quoted are the result of tests on representative samples, and the product supplied may not conform in all respects. Qenos Pty Ltd reserves the right to make any improvements or amendments to the composition of any grade or product without alteration to the code number. In using Qenos Pty Ltd's products, you must establish for yourself the most suitable formulation, production method and control tests, to ensure the uniformity and quality of your product in compliance with all laws. Qenos Pty Ltd ACN 054 196 771 is the registered user of the Qenos Logo which is registered trademark of Qenos Pty Ltd. "Alkatuff" is a trademark of Qenos Pty Ltd.

