

This form is to be used by an appointed competent person for the purposes of section 10 of the *Building Act 1975* and sections 73 and 77 of the *Building Regulation 2021* (Design-specification certificate) stating that an aspect of building work or specification will, if installed or carried out as stated in this form, comply with the building assessment provisions.

Additional explanatory information is included in the Appendix at the end of this form.

1. Property description

This section need only be completed if details of street address and property description are applicable.

E.g. in the case of (standard/generic) pool design/shell manufacture and/or patio and carport systems this section may not be applicable.

The description must identify all land the subject of the application.

The lot and plan details (e.g. SP/RP) are shown on title documents or a rates notice.

If the plan is not registered by title, provide previous lot and plan details.

Street address			
		Suburb/locality	
State	Choose an item.	Postcode	
Lot and plan details (<i>attach list if necessary</i>)			
Local government area the land is situated in			

2. Description of aspect/s certified

Clearly describe the extent of work covered by this certificate, e.g. all structural aspects of the steel roof beams.

<p>Cruiser Pool – Structural adequacy of Poly Pool 5m long x 2.5m wide x 1.4m high. Pool manufactured from Microstuff 6110UV moulded under heat. 8mm nominal wall thickness. For any intended use, either partially inground or buried, you must consult your hydraulic engineer for installation requirement</p>

3. Basis of certification

Detail the basis for giving the certificate and the extent to which tests, specifications, rules, standards, codes of practice and other publications were relied upon.

<p>AS1170.1, AS 1664.1, AS4100 Foundation material to have a minimum bearing capacity of 100kPa Polyethylene minimum tensile yield strength – 19.5MPa</p>

4. Reference documentation

Clearly identify any relevant documentation, e.g. numbered structural engineering plans.

<p>Document Number D-QU-1014 attached.</p>

5. Building certifier reference number and building development approval number

Building certifier reference number		Building development application number (if available)	
-------------------------------------	--	--------------------------------------------------------	--

6. Appointed competent person details

Under Part 6 of the Building Regulation a person must be assessed as a competent for the type of work (design-specification) by the relevant building certifier.

Name (in full)	PENG LEONG		
Company name (if applicable)	MAJORIS STRUCTURAL INSPECTIONS		
Contact person	PENG LEONG		
Business phone number		Mobile	0450 811187
Email address	Structural.inspections@yahoo.com		
Postal address	P O Box 4698		
		Suburb/locality	Forest Lake
State	QLD	Postcode	4078
Licence class or registration type (if applicable)	RPEQ 09178		
Licence or registration number (if applicable)			

9. Signature of appointed competent person

This certificate must be signed by the individual assessed and appointed by the building certifier as competent to give design-specification help.

Signature		Date	4/11/2022
-----------	-------------------------------------------------------------------------------------	------	-----------

LOCAL GOVERNMENT USE ONLY

Date received	Click or tap to enter a date.	Reference number/s	
---------------	-------------------------------	--------------------	--

Appendix – explanatory information

IMPORTANT NOTE: it is an offence for a competent person to give a building certifier a document, including this form, that the person knows or reasonably suspects, is false or misleading.

Who can complete this certificate? (sections 10 of the *Building Act 1975* (Building Act) and 73 of Building Regulation 2021 (BR 2021))

A building certifier can accept from a competent person (design – specifications) a certificate stating that the competent person has assessed the building design or specification for the aspect of building work, and it will, if installed or carried out under the certificate, comply with the building assessment provisions, including any relevant standards and codes.

Schedule 10 of the BR 2021 defines *building design or specification* as any material, system, method of building or other thing related to the design of or specifications for building work.

For a competent person to meet the regulation requirements (section 77 of the BR 2021) they must substantially complete all sections of this form, including information, such as the design of a particular material, system, method of building or that a building element complies with the Building Code of Australia or a provision of the Queensland Development Code. It is also important that the details of the relevant reference documents are included, for example, the applicable Australian Standards or other technical provisions that may be applicable to the subject work.

What is the purpose of this form? (section 10 of the *Building Act 1975*)

The information in this form informs the building certifier's decision making when they are assessing a building development application and issuing the building development approval for the building work the subject of the certificate (form).

When is this form not required?

The assessment of some building applications will be entirely within the expertise of the relevant building certifier and therefore they may not seek the help of a competent person. In these instances, this form is not required.

Is a manufacturer or supplier required under the BR 2021 to complete and sign this Form 15, if requested?

No. A manufacturer or supplier of building materials is not required to complete and give this form or any aspect and inspection certificates if requested by a construction contractor, builder, appointed competent person, or a building certifier.

However, a manufacturer or supplier may give the construction contractor, builder, competent person or the building certifier evidence of suitability such as a manufacturer's statement for an aspect or material that it is compliant with the relevant reference documents in the BCA i.e. the applicable Australian Standard/s.

What if there is not enough space for all the supporting material/documents?

Items 2, 3 and 4 requires the competent person to clearly identify the extent of the assessment that was undertaken for aspect/s of work identified in this form.

For instance, there is provision for material such as specifications, standards, codes or other relevant publications to be referenced in the form. However, if the space in the form is not sufficient to accommodate all of this material, you can create and refer to additional material in an addendum or attachment to the form.

The form is also available in a Microsoft Word version, that you can download and edit to include additional material in the relevant parts of the form. **Note:** that editing the form in the Microsoft Word version may cause the relevant boxes to expand and increase the length of the document. This is acceptable and does not change the approved form, provided the section text (description on the left-hand side of the page) is not altered.

Appointed competent person (design or specification) – (sections 34 and 36 of the BR 2021)

A building certifier must assess and decide to appoint an individual as a competent person before they can, as a competent person, give design-specification help. The building certifier is required to keep detailed records about what was considered when appointing a competent person.

A building certifier must be satisfied that an individual is competent to give the type of inspection help having regard to the individual's experience, qualifications and skills and if required by law to hold a licence or registration, that the individual is appropriately registered or licensed.

An individual is appointed as competent to give design-specification help on or from a particular day. The building certifier can also decide an individual is a competent person (design-specification) and a competent person (inspection) at the same time or for the same systems or components of the work.

For further information about assessment of someone as a competent person refer to the **Guideline for the assessment of competent persons**.

PRIVACY NOTICE

The Department of Energy and Public Works is collecting personal information as required under the *Building Act 1975*. This information may be stored by the Department, and will be used for administration, compliance, statistical research and evaluation of building laws. Your personal information will be disclosed to other government agencies, local government authorities and third parties for purposes relating to administering and monitoring compliance with the *Building Act 1975*. Personal information will otherwise only be disclosed to third parties with your consent or unless authorised or required by law.

Cruiser Pool & frame Drawings

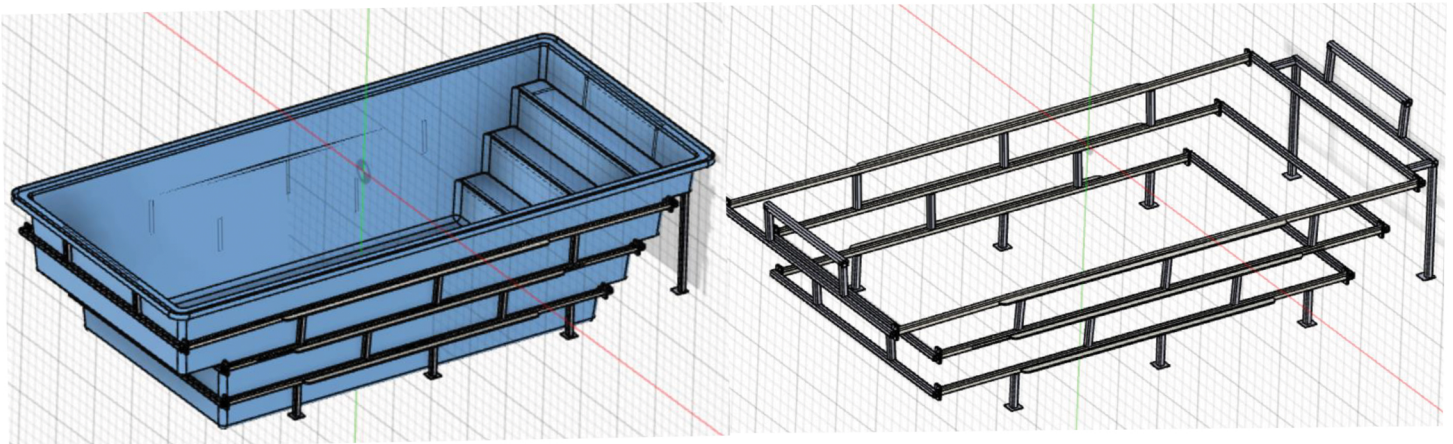

Geometry

